



*Il vostro partner per il controllo qualità in linea*



## Metal Detector

### **MDC 11**

- *100 programmi prodotti memorizzabili*
- *Struttura in acciaio INOX IP65*
- *Ridottissima area libera da metalli*



# Metal Detector



## MDC 11

### Caratteristiche tecniche

- Alimentazione elettrica 230V 50/60Hz monofase
- Assorbimento 200W
- Versione Inox IP65

### Accessori

- Validazione FDA
- Interfaccia seriale RS232
- Sensore controllo avvenuto scarto
- Raccolta dati USB



### Descrizione MDC11

Principio di funzionamento: digitale a immagine bidimensionale

N° Programmi 100

Pannello operatore display grafico, tastiera alfanumerica

Visualizzazione immagine prodotto

Introduzione dati alfanumerici

Funzione self check

Possibilità di regolazione fase

Compensazione automatica effetto prodotto (Tracking)

Elettronica separata

Uscita allarme funzionale e di processo

Totalizzatore pezzi OK e scarti

Storico eventi

Password per l'accesso alle impostazioni modificabile

Funzione data e ora

Stampa immagine

Stampa dati elaborati

Rispondenza a normative ISO-FDA HACCP



Diametro apertura  
passaggio prodotto

- Ø 130 mm
- Ø 150 mm
- Ø 210 mm
- Ø 240 mm

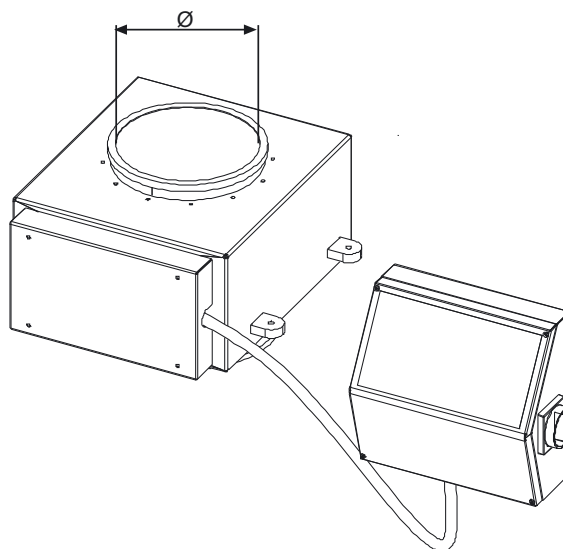

### Prisma Industriale S.r.l.

- Via La Bionda, 17 - 43036 Fidenza - Parma - Italy • Tel. +39 0524 527270 - Fax +39 0524 524142
- www.prismaindustriale.com • info@prismaindustriale.com



Azienda con sistema di gestione  
certificato ISO 9001 - ISO 14001