



metal detector
metal detector
metal detector

MDB





metal detector

MDB

Electronical specifications

- Digital elaboration of the signal
- Keypad and display with two LED numbers
- Signal indication with two LED bars
- RS 232 serial port
- Network ready
- Rejection synchronism photocell
- 100 storable product programs

Mechanical specifications

- Stainless steel painted (white) with IP55 protection

Sensibility

These types of Metal Detector studied for being insensitive to the Aluminum are much sensitive to the iron. The level of sensibility can be inferior to a sphere Ø 1,0 mm for the smaller mouth (100x300).

The definitive sensibility is tied to the characteristics of the material to control.

Operation logic

When a package passes in the opening of the metal detector moves to inside of a powerful magnetic field (fig. 1). The metallic particles change the magnetic field generating one small tension that comes found and amplified (fig. 2).

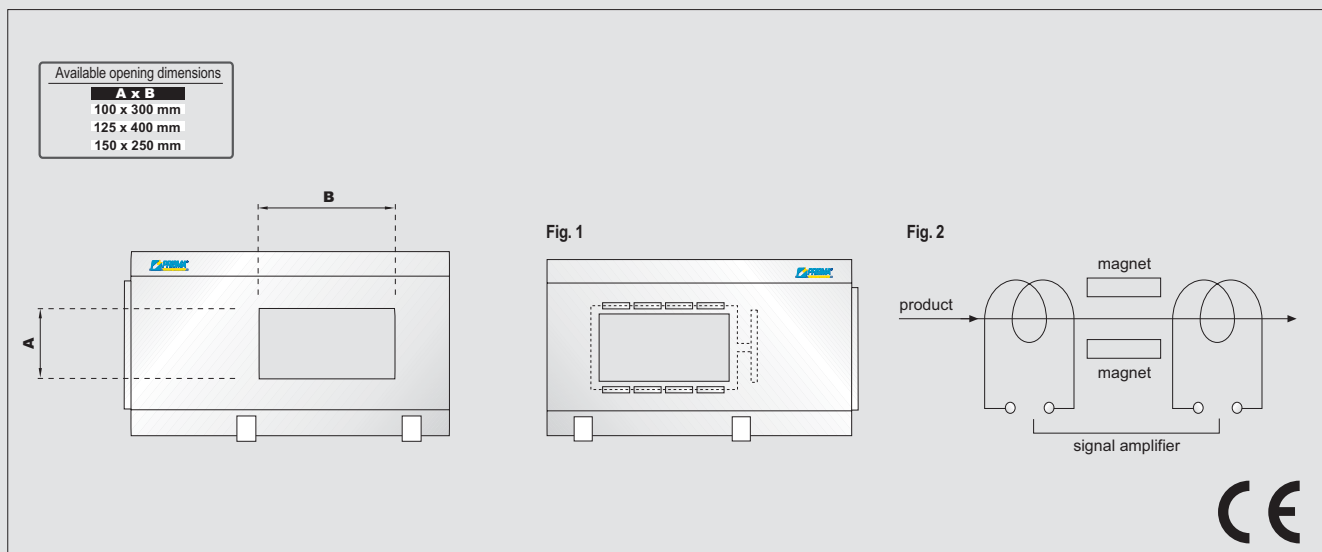

© 2002 - 2005 PRISMA INDUSTRIALE - REV 09/2005

